

PHYSICS

Section - A (Single Correct Answer)

1. A block of $\sqrt{3}$ kg is attached to a string whose other end is attached to the wall. An unknown force F is applied so that the string makes an angle of 30° with the wall. The tension T is : (Given $g = 10 \text{ ms}^{-2}$)

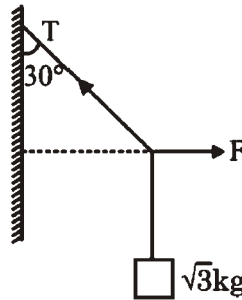

- (A) 20 N (B) 25 N (C) 10 N (D) 15 N
2. A flask contains hydrogen and oxygen in the ratio of 2 : 1 by mass at temperature 27°C . The ratio of average kinetic energy per molecule of hydrogen and oxygen respectively is :
- (A) 2 : 1 (B) 1 : 1 (C) 1 : 4 (D) 4 : 1
3. The equivalent resistance between A and B is

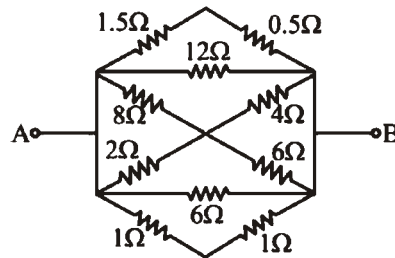

- (A) $2/3 \Omega$ (B) $1/2 \Omega$ (C) $3/2 \Omega$ (D) $1/3 \Omega$
4. Given below are two statements : one is labelled as **Assertion A** and the other is labelled as **Reason R**.

Assertion A : The nuclear density of nuclides $^{10}_5\text{B}$, ^6_3Li , $^{56}_{26}\text{Fe}$, $^{20}_{10}\text{Ne}$ and $^{209}_{83}\text{Bi}$ can be arranged as

$$\rho_{\text{Bi}}^{\text{N}} > \rho_{\text{Fe}}^{\text{N}} > \rho_{\text{Ne}}^{\text{N}} > \rho_{\text{B}}^{\text{N}} > \rho_{\text{Li}}^{\text{N}}$$

Reason R : The radius R of nucleus is related to its mass number A as $R = R_0 A^{1/3}$, where R_0 is a constant.

In the light of the above statement, choose the **correct** answer from the options given below :

- (A) Both **A** and **R** are true and **R** is the correct explanation of **A**
- (B) **A** is false but **R** is true
- (C) **A** is true but **R** is false
- (D) Both **A** and **R** are true but **R** is **NOT** the correct explanation of **A**

5. A thin prism P_1 with an angle 6° and made of glass of refractive index 1.54 is combined with another prism P_2 made from glass of refractive index 1.72 to produce dispersion without average deviation. The angle of prism P_2 is :

(A) 6° (B) 1.3° (C) 7.8° (D) 4.5°

6. The output Y for the inputs A and B of circuit is given by

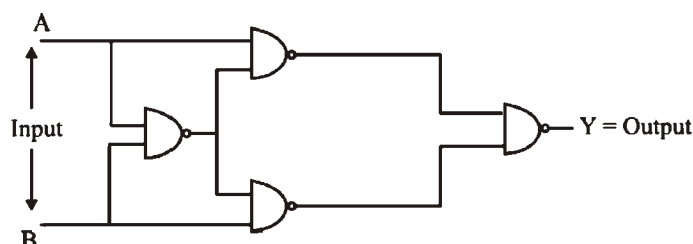

Truth table of the shown circuit is :

(A)	A	B	Y	(B)	A	B	Y	(C)	A	B	Y	(D)	A	B	Y
	0	0	1		0	0	1		0	0	0		0	0	0
	0	1	1		0	1	0		0	1	1		0	1	1
	1	0	1		1	0	0		1	0	1		1	0	1
	1	1	0		1	1	1		1	1	1		1	1	0

7. A vehicle travels 4 km with speed of 3 km/h and another 4 km with speed of 5 km/h, then its average speed is :

(A) 4.25 km/h (B) 3.50 km/h (C) 4.00 km/h (D) 3.75 km/h

8. As shown in the figure, a point charge Q is placed at the centre of conducting spherical shell of inner radius a and outer radius b. The electric field due to charge Q in three different regions I, II and III is given by : (I : $r < a$, II : $a < r < b$, III : $r > b$)

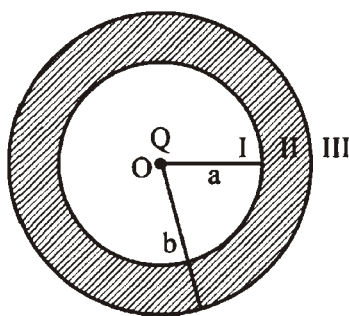

(A) $E_I = 0, E_{II} = 0, E_{III} \neq 0$ (B) $E_I \neq 0, E_{II} = 0, E_{III} \neq 0$
 (C) $E_I \neq 0, E_{II} = 0, E_{III} = 0$ (D) $E_I = 0, E_{II} = 0, E_{III} = 0$

9. As shown in the figure, a current of 2A flowing in an equilateral triangle of side $4\sqrt{3}$ cm. The magnetic field at the centroid O of the triangle is : (Neglect the effect of earth's magnetic field.)

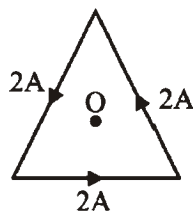

(A) $4\sqrt{3} \times 10^{-4} \text{ T}$ (B) $4\sqrt{3} \times 10^{-5} \text{ T}$ (C) $\sqrt{3} \times 10^{-4} \text{ T}$ (D) $3\sqrt{3} \times 10^{-5} \text{ T}$

10. In the given circuit, rms value of current (I_{rms}) through the resistor R is :

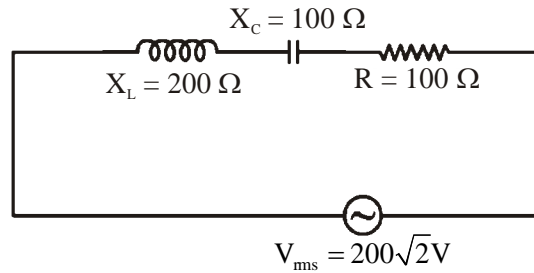

- (A) 2A (B) $\frac{1}{2}$ A (C) 20 A (D) $2\sqrt{2}$ A
11. A machine gun of mass 10 kg fires 20 g bullets at the rate of 180 bullets per minute with a speed of 100 m s^{-1} each. The recoil velocity of the gun is :
- (A) 0.02 m/s (B) 2.5 m/s (C) 1.5 m/s (D) 0.6 m/s
12. Given below are **two** statements : one is labelled as **Assertion A** and the other is labelled as **Reason R**.

Assertion A : Efficiency of a reversible heat engine will be highest at -273°C temperature of cold reservoir.

Reason R : The efficiency of Carnot's engine depends not only on temperature of cold reservoir but it depends on the temperature of hot reservoir too and is given as $\eta = \left(1 - \frac{T_2}{T_1}\right)$. In the light of the above

statements, choose the **correct** answer from the options given below :

- (A) **A** is true but **R** is false
 (B) Both **A** and **R** are true but **R** is **NOT** the correct explanation of **A**
 (C) **A** is false but **R** is true
 (D) Both **A** and **R** are true and **R** is the correct explanation of **A**
13. Match List I with List II.

List-I	List-II
A. Torque	I. $\text{kg m}^{-1} \text{s}^{-2}$
B. Energy density	II. kg ms^{-1}
C. Pressure gradient	III. $\text{kg m}^{-2} \text{s}^{-2}$
D. Impulse	IV. $\text{kg m}^2 \text{s}^{-2}$

Choose the **correct** answer from the options given below :

- (A) A \rightarrow IV, B \rightarrow III, C \rightarrow I, D \rightarrow II (B) A \rightarrow I, B \rightarrow IV, C \rightarrow III, D \rightarrow II
 (C) A \rightarrow IV, B \rightarrow I, C \rightarrow II, D \rightarrow III (D) A \rightarrow IV, B \rightarrow I, C \rightarrow III, D \rightarrow II
14. For a simple harmonic motion in a mass spring system shown, the surface is frictionless. When the mass of the block is 1 kg, the angular frequency is ω_1 . When the mass block is 2 kg the angular frequency is ω_2 . The ratio ω_2/ω_1 is :

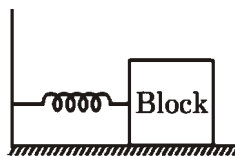

- (A) $\sqrt{2}$ (B) $\frac{1}{\sqrt{2}}$ (C) 2 (D) $\frac{1}{2}$

15. An electron accelerated through a potential difference V_1 has a de-Broglie wavelength of λ . When the potential is changed to V_2 , its de-Broglie wavelength increases by 50%. The value of $\left(\frac{V_1}{V_2}\right)$ is equal to :

- (A) 3 (B) 9/4 (C) 3/2 (D) 4

16. Match List I with List II :

List-I	List-II
A. Attenuation	I. Combination of a receiver and transmitter.
B. Transducer	II. Process of retrieval of information from the carrier wave at received
C. Demodulation	III. Converts one form of energy into another
D. Repeater	IV. Loss of strength of a signal while propagating through a medium

Choose the correct answer from the options given below :

- (A) A → I, B → II, C → III, D → IV (B) A → II, B → III, C → IV, D → I
 (C) A → IV, B → III, C → I, D → II (D) A → IV, B → III, C → II, D → I

17. A current carrying rectangular loop PQRS is made of uniform wire. The length $PR = QS = 5$ cm and $PQ = RS = 100$ cm. If ammeter current reading changes from I to $2I$, the ratio of magnetic forces per unit length on the wire PQ due to wire RS in the two cases respectively $f_{PQ}^1 : f_{PQ}^{2I}$ is :

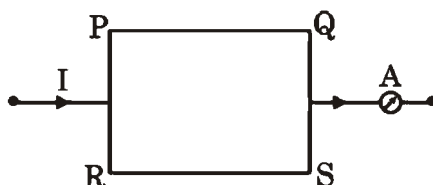

- (A) 1 : 2 (B) 1 : 4 (C) 1 : 5 (D) 1 : 3

18. A force is applied to a steel wire 'A', rigidly clamped at one end. As a result elongation in the wire is 0.2 mm. If same force is applied to another steel wire 'B' of double the length and a diameter 2.4 times that of the wire 'A', the elongation in the wire 'B' will be (wires having uniform circular cross sections)

- (A) 6.06×10^{-2} mm (B) 2.77×10^{-2} mm (C) 3.0×10^{-2} mm (D) 6.9×10^{-2} mm

19. An object is allowed to fall from a height R above the earth, where R is the radius of earth. Its velocity when it strikes the earth's surface, ignoring air resistance, will be :

- (A) $2\sqrt{gR}$ (B) \sqrt{gR} (C) $\sqrt{\frac{gR}{2}}$ (D) $\sqrt{2gR}$

20. A point source of 100 W emits light with 5% efficiency. At a distance of 5 m from the source, the intensity produced by the electric field component is :

- (A) $\frac{1}{2\pi} \frac{W}{m^2}$ (B) $\frac{1}{4\pi} \frac{W}{m^2}$ (C) $\frac{1}{10\pi} \frac{W}{m^2}$ (D) $\frac{1}{20\pi} \frac{W}{m^2}$

SECTION - B

21. A faulty thermometer reads 5°C in melting ice and 95°C in steam. The correct temperature on absolute scale will be..... K when the faulty thermometer reads 41°C .
22. If the potential difference between B and D is zero, the value of x is $\frac{1}{n}\Omega$. The value of n is

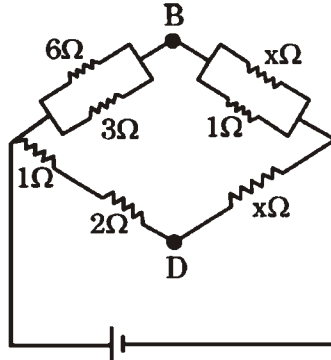

23. The velocity of a particle executing SHM varies with displacement (x) as $4v^2 = 50 - x^2$. The time period of oscillations is $\frac{x}{7}$ s. The value of x is (Take $\pi = \frac{22}{7}$)
24. In a Young's double slit experiment, the intensities at two points, for the path difference $\lambda/4$ and $\lambda/3$ (λ being the wavelength of light used) are I_1 and I_2 respectively. If I_0 denotes the intensity produced by each one of the individual slits, then $\frac{I_1 + I_2}{I_0} = \dots\dots$
25. A radioactive nucleus decays by two different process. The half life of the first process is 5 minutes and that of the second process is 30s. The effective half-life of the nucleus is calculated to be $\frac{\alpha}{11}$ s. The value of α is
26. A body of mass 2 kg is initially at rest. It starts moving unidirectionally under the influence of a source of constant power P . Its displacement in 4s is $\frac{1}{3}\alpha^2\sqrt{P}$ m. The value of α will be
27. As shown in figure, a cuboid lies in a region with electric field $E = 2x^2\hat{i} - 4y\hat{j} + 6\hat{k}$ N/C. The magnitude of charge within the cuboid is $n\epsilon_0$ C. The value of n is (if dimension of cuboid is $1 \times 2 \times 3$ m³)

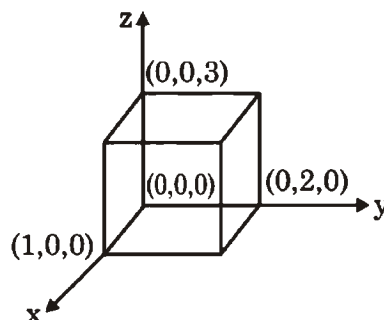

28. In an ac generator, a rectangular coil of 100 turns each having area $14 \times 10^{-2} \text{ m}^2$ is rotated at 360 rev/min about an axis perpendicular to a uniform magnetic field of magnitude 3.0 T. The maximum value of the emf produced will be _____ V. (Take $\pi = \frac{22}{7}$)
29. A stone tied to 180 cm long string at its end is making 28 revolutions in horizontal circle in every minute. The magnitude of acceleration of stone is $\frac{1936}{x} \text{ ms}^{-2}$. The value of x _____. (Take $\pi = \frac{22}{7}$)
30. A uniform disc of mass 0.5 kg and radius r is projected with velocity 18 m/s at $t = 0$ s on a rough horizontal surface. It starts off with a purely sliding motion at $t = 0$ s. After 2s it acquires a purely rolling motion (see figure). The total kinetic energy of the disc after 2s will be _____ J (given, coefficient of friction is 0.3 and $g = 10 \text{ m/s}^2$).

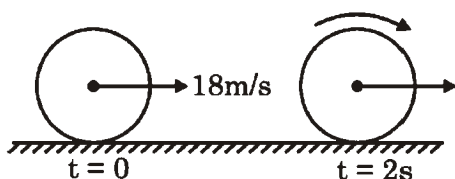
**CHEMISTRY****Section - A (Single Correct Answer)**

31. Which of the following reaction is **correct** ?



32. The most stable carbocation for the following is

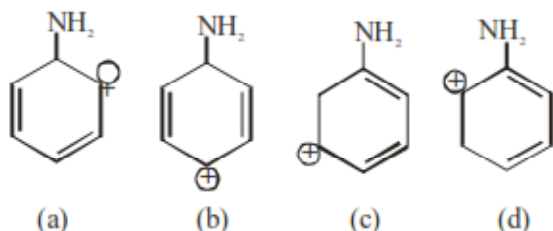

- (A) c (B) d (C) b (D) a

33. The **correct** order of pK_a values for the following compounds is

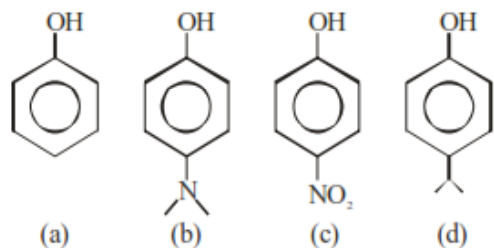

- (A) $c > a > d > b$ (B) $b > d > a > c$
 (C) $b > a > d > c$ (D) $a > b > c > d$

34. Decreasing order towards S_N1 reaction for the following compounds is

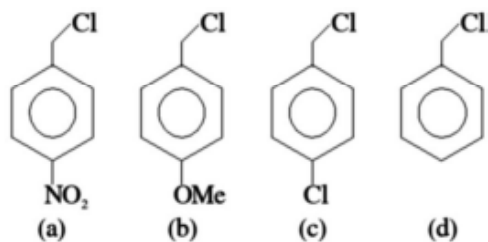

- (A) $a > c > d > b$ (B) $a > b > c > d$ (C) $b > d > c > a$ (D) $d > b > c > a$

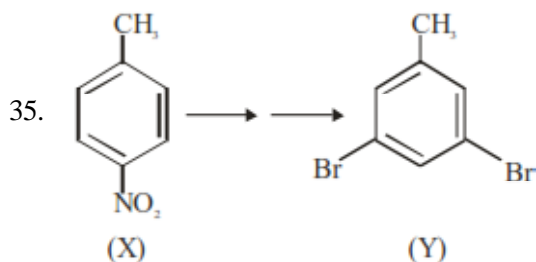

In the above conversion of compound (X) to product (Y), the sequence of reagents to be used will be

- (A) (i) Br_2 , Fe (ii) Fe, H^+ (iii) $LiAlH_4$ (B) (i) $Br_2(aq)$ (ii) $LiAlH_4$ (iii) H_3O^+
 (C) (i) Fe, H^+ (ii) $Br_2(aq)$ (iii) HNO_2 (iv) $CuBr$ (D) (i) Fe, H^+ (ii) $Br_2(aq)$ (iii) HNO_2 (iv) H_3PO_2
36. Maximum number of electrons that can be accommodated in shell with $n = 4$ are
 (A) 16 (B) 32 (C) 50 (D) 72
37. Match List I with List II :

List I (Complexes)	List II (Hybridisation)
(A) $[Ni(CO)_4]$	I sp^3
(B) $[Cu(NH_3)_4]^{2+}$	II dsp^2
(C) $[Fe(NH_3)_6]^{2+}$	III sp^3d^2
(D) $[Fe(H_2O)_6]^{2+}$	IV d^2sp^3
(A) A – II, B – I, C – III, D – IV	(B) A – I, B – II, C – III, D – IV
(C) A – II, B – I, C – IV, D – III	(D) A – I, B – II, C – IV, D – III

38. The Cl – Co – Cl bond angle values in a fac- $[Co(NH_3)_3Cl_3]$ complex is/are
 (A) 90° & 180° (B) 90° (C) 180° (D) 90° & 120°
39. Given below are two statements : One is labelled as Assertion A and the other is labelled as Reason R.

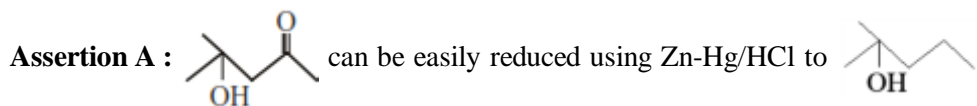

Reason R : $Zn-Hg/HCl$ is used to reduce carbonyl group to $-CH_2-$ group.

In the light of the above statements, choose the correct answer from the options given below.

- (A) A is false but R is true
 (B) A is true but R is false
 (C) Both A and R are true but R is not the correct explanation of A
 (D) Both A and R are true and R is the correct explanation of A

40. Chlorides of which metal are soluble in organic solvents.
 (A) Ca (B) Mg (C) K (D) Be

41. Given below are two statements :

One is labelled as Assertion A and the other labelled as Reason R.

Assertion A : Antihistamines do not affect the secretion of acid in stomach.

Reason R : Antiallergic and antacid drugs work on different receptors.

In the light of the above statements, choose the **correct** answer from the options given below.

- (A) A is false but R is true
 (B) Both A and R are true and R is the correct explanation of A
 (C) A is true but R is false
 (D) Both A and R are true but R is not the correct explanation of A.
42. The wave function (Ψ) of 2s is given by

$$\Psi_{2s} = \frac{1}{2\sqrt{2\pi}} \left(\frac{1}{a_0} \right)^{1/2} \left(2 - \frac{r}{a_0} \right) e^{-r/2a_0}$$

At $r = r_0$, radial node is formed. Thus, r_0 in terms of a_0 .

- (A) $r_0 = a_0$ (B) $r_0 = 4a_0$ (C) $r_0 = \frac{a_0}{2}$ (D) $r_0 = 2a_0$
43. KMnO_4 oxidises I⁻ in acidic and neutral/faintly alkaline solution, respectively to
 (A) I₂ and IO₃⁻ (B) IO₃⁻ and I₂ (C) IO₃⁻ and IO₃⁻ (D) I₂ and I₂
44. Bond dissociation energy of E–H bond of the “H₂E” hydrides of group 16 elements (given below), follows order.
A. O **B.** S **C.** Se **D.** Te
 (A) A > B > C > D (B) A > B > D > C (C) B > A > C > D (D) D > C > B > A
45. The water quality of a pond was analysed and its BOD was found to be 4. The pond has
 (A) Highly polluted water (B) Water has high amount of fluoride compounds
 (C) Very clean water (D) Slightly polluted water
46. Match List I with List II :

List I (Mixture)	List II (Separation Technique)
A. $\text{CHCl}_3 + \text{C}_6\text{H}_5\text{NH}_2$	I. Steam distillation
B. $\text{C}_6\text{H}_{14} + \text{C}_5\text{H}_{12}$	II. Differential extraction
C. $\text{C}_6\text{H}_5\text{NH}_2 + \text{H}_2\text{O}$	III. Distillation
D. Organic compound in H_2O	IV. Fractional distillation
(A) A-IV, B-I, C-III, D-II	(B) A-III, B-IV, C-I, D-II
(C) A-II, B-I, C-III, D-IV	(D) A-III, B-I, C-IV, D-II

47. Boric acid in solid, whereas BF_3 is gas at room temperature because of
 (A) Strong ionic bond in Boric acid
 (B) Strong van der Waal's interaction in Boric acid
 (C) Strong hydrogen bond in Boric acid
 (D) Strong covalent bond in BF_3

48. Given below are two statements :

Statement I: During Electrolytic refining, the pure metal is made to act as anode and its impure metallic form is used as cathode.

Statement II: During the Hall-Heroult electrolysis process, purified Al_2O_3 is mixed with Na_3AlF_6 to lower the melting point of the mixture.

In the light of the above statements, choose the most appropriate answer from the options given below.

- (A) Statement I is incorrect but Statement II is correct
 (B) Both Statement I and Statement II are incorrect
 (C) Statement I is correct but Statement II is incorrect
 (D) Both Statement I and Statement II are correct

49. Formulae for Nessler's reagent is :

- (A) KHg_2I_2 (B) KHgI_3 (C) K_2HgI_4 (D) HgI_2

50. 1 L, 0.02 M solution of $[\text{Co}(\text{NH}_3)_5\text{SO}_4]\text{Br}$ is mixed with 1 L, 0.02 M solution of $[\text{Co}(\text{NH}_3)_5\text{Br}]\text{SO}_4$. The resulting solution is divided into two equal parts (X) and treated with excess AgNO_3 solution and BaCl_2 solution respectively as shown below.

1 L Solution (X) + AgNO_3 solution (excess) \rightarrow Y

1 L Solution (X) + BaCl_2 solution (excess) \rightarrow Z

The number of moles of Y & Z respectively are

- (A) 0.02, 0.02 (B) 0.01, 0.01 (C) 0.02, 0.01 (D) 0.01, 0.02

SECTION - B

51. 1 mole of ideal gas is allowed to expand reversibly and adiabatically from a temperature of 27°C . The work done is 3 kJ mol^{-1} . The final temperature of the gas is _____ K.

[Nearest integer]

Given : $C_v = 20 \text{ J mol}^{-1} \text{ K}^{-1}$.

52. Iron oxide FeO , crystallises in a cubic lattice with a unit cell edge length of 5.0 \AA . If density of the FeO in the crystal is 4.0 g cm^{-3} , then the number of FeO units present per unit cell is _____.

[Nearest integer]

Given : Molar mass of Fe and O is 56 and 16 g mol^{-1} respectively.

$N_A = 6.0 \times 10^{23} \text{ mol}^{-1}$

53. An organic compound undergoes first order decomposition. If the time taken for the 60% decomposition is 540 s, then the time required for 90% decomposition will be _____ s.

[Nearest integer]

Given : $\ln 10 = 2.3$; $\log 2 = 0.3$

54. Lead storage battery contains 38% by weight solution of H_2SO_4 . The van't Hoff factor is 2.67 at this concentration. The temperature in Kelvin at which the solution in the battery will freeze is _____.

[Nearest integer]

Given : $K_f = 1.8 \text{ K kg mol}^{-1}$

55. Consider the following equation :

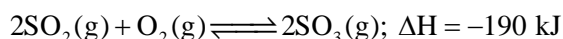

The number of factors which will increase the yield of SO_3 at equilibrium from the following is _____.

- A. Increasing temperature
 B. Increasing pressure
 C. Adding more SO₂
 D. Adding more O₂
 E. Addition of catalyst

56. The graph of $\log \frac{x}{m}$ vs $\log p$ for an adsorption process is a straight line inclined at an angle of 45° with intercept equal to 0.6020. The mass of gas adsorbed per unit mass of adsorbent at the pressure of 0.4 atm is _____ $\times 10^{-1}$.

[Nearest integer]

Given : $\log 2 = 0.3010$

57. Number of compounds from the following which will not dissolve in cold NaHCO₃ and NaOH solutions but will dissolve in hot NaOH solution is _____.

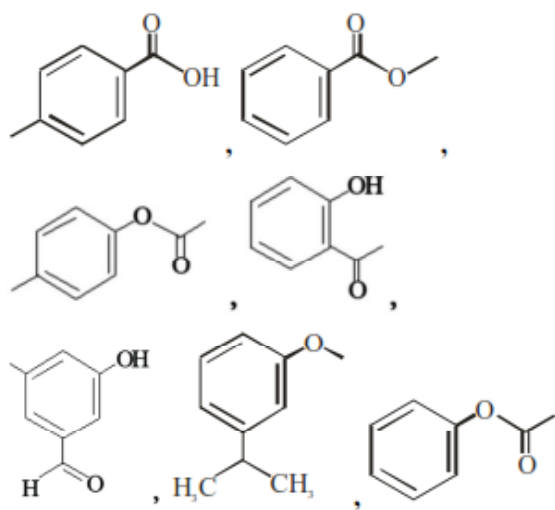

58. A short peptide on complete hydrolysis produces 3 moles of glycine (G), two moles of leucine (L) and two moles of valine (V) per mole of peptide. The number of peptide linkages in it are _____.

59. The strength of 50 volume solution of hydrogen peroxide is _____ g/L.

[Nearest integer]

Given :

Molar mass of H₂O₂ is 34 g mol⁻¹.

Molar volume of gas at STP = 22.7 L.

60. The electrode potential of the following half cell at 298 K.

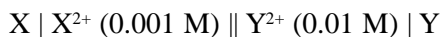

is _____ $\times 10^{-2}$ V.

[Nearest integer]

Given : $E_{X^{2+}/X}^{\circ} = -2.36 \text{ V}$

$E_{Y^{2+}/Y}^{\circ} = +0.36 \text{ V}$

$$\frac{2.303 RT}{F} = 0.06 \text{ V}$$

61. Consider the following statements :

P : I have fever

Q : I will not take medicine

R : I will take rest

The statement “If I have fever, then I will take medicine and I will take rest” is equivalent to :

(A) $((\sim P) \vee \sim Q) \wedge ((\sim P) \vee R)$

(B) $((\sim P) \vee \sim Q) \wedge ((\sim P) \vee \sim R)$

(C) $(P \vee Q) \wedge ((\sim P) \vee R)$

(D) $(P \vee \sim Q) \wedge (P \vee \sim R)$

62. Let A be a point on the x-axis. Common tangents are drawn from A to the curves $x^2 + y^2 = 8$ and $y^2 = 16x$. If one of these tangents touches the two curves at Q and R, then $(QR)^2$ is equal to

(A) 64

(B) 76

(C) 81

(D) 72

63. Let q be the maximum integral value of p in $[0, 10]$ for which the roots of the equation $x^2 - px + \frac{5}{4}p = 0$ are rational. Then the area of the region $\{(x, y) : 0 \leq y \leq (x - q)^2, 0 \leq x \leq q\}$ is :

(A) 243

(B) 25

(C) $\frac{125}{3}$

(D) 164

64. If the functions $f(x) = \frac{x^3}{3} + 2bx + \frac{ax^2}{2}$ and $g(x) = \frac{x^3}{3} + ax + bx^2$, $a \neq 2b$ have a common extreme point, then $a + 2b + 7$ is equal to :

(A) 4

(B) $\frac{3}{2}$

(C) 3

(D) 6

65. The range of the function $f(x) = \sqrt{3-x} + \sqrt{2+x}$ is :

(A) $[\sqrt{5}, \sqrt{10}]$

(B) $[2\sqrt{2}, \sqrt{11}]$

(C) $[\sqrt{5}, \sqrt{13}]$

(D) $[\sqrt{2}, \sqrt{7}]$

66. The solution of the differential equation $\frac{dy}{dx} = -\left(\frac{x^2 + 3y^2}{3x^2 + y^2}\right)$, $y(1) = 0$ is

(A) $\log_e |x + y| - \frac{xy}{(x + y)^2} = 0$

(B) $\log_e |x + y| + \frac{xy}{(x + y)^2} = 0$

(C) $\log_e |x + y| + \frac{2xy}{(x + y)^2} = 0$

(D) $\log_e |x + y| - \frac{2xy}{(x + y)^2} = 0$

67. Let $x = (8\sqrt{3} + 13)^{13}$ and $y = (7\sqrt{2} + 9)^9$. If $[t]$ denotes the greatest integer $\leq t$, then

(A) $[x] + [y]$ is even

(B) $[x]$ is odd but $[y]$ is even

(C) $[x]$ is even but $[y]$ is odd

(D) $[x]$ and $[y]$ are both odd

68. A vector \vec{v} in the first octant is inclined to the x-axis at 60° , to the y-axis at 45° and to the z-axis at an acute angle. If a plane passing through the points $(\sqrt{2}, -1, 1)$ and (a, b, c) , is normal to \vec{v} , then

(A) $\sqrt{2}a + b + c = 1$

(B) $a + b + \sqrt{2}c = 1$

(C) $a + \sqrt{2}b + c = 1$

(D) $\sqrt{2}a - b + c = 1$

69. Let f , g and h be the real valued functions defined on \mathbb{R} as $f(x) = \begin{cases} \frac{x}{|x|}, & x \neq 0 \\ 1, & x = 0 \end{cases}$,
 $g(x) = \begin{cases} \frac{\sin(x+1)}{(x+1)}, & x \neq -1 \\ 1, & x = -1 \end{cases}$ and $h(x) = 2[x] - f(x)$, where $[x]$ is the greatest integer $\leq x$. Then the value of $\lim_{x \rightarrow 1} g(h(x-1))$ is
 (A) 1 (B) $\sin(1)$ (C) -1 (D) 0
70. The number of ways of selecting two numbers a and b , $a \in \{2, 4, 6, \dots, 100\}$ and $b \in \{1, 3, 5, \dots, 99\}$ such that 2 is the remainder when $a + b$ is divided by 23 is
 (A) 186 (B) 54 (C) 108 (D) 268
71. If P is a 3×3 real matrix such that $P^T = aP + (a-1)I$, where $a > 1$, then
 (A) P is a singular matrix (B) $|\text{Adj } P| > 1$
 (C) $|\text{Adj } P| = \frac{1}{2}$ (D) $|\text{Adj } P| = 1$
72. Let $\lambda \in \mathbb{R}$, $\vec{a} = \lambda\hat{i} + 2\hat{j} - 3\hat{k}$, $\vec{b} = \hat{i} - \lambda\hat{j} + 2\hat{k}$. If $((\vec{a} + \vec{b}) \times (\vec{a} \times \vec{b})) \times (\vec{a} - \vec{b}) = 8\hat{i} - 40\hat{j} - 24\hat{k}$, then $|\lambda(\vec{a} + \vec{b}) \times (\vec{a} - \vec{b})|^2$ is equal to
 (A) 140 (B) 132 (C) 144 (D) 136
73. Let \vec{a} and \vec{b} be two vectors. Let $|\vec{a}| = 1$, $|\vec{b}| = 4$ and $\vec{a} \cdot \vec{b} = 2$. If $\vec{c} = (2\vec{a} \times \vec{b}) - 3\vec{b}$, then the value of $\vec{b} \cdot \vec{c}$ is
 (A) -24 (B) -48 (C) -84 (D) -60
74. Let $a_1 = 1$ and let $a_1, a_2, a_3, a_4, \dots$ be consecutive natural numbers. Then $\tan^{-1}\left(\frac{1}{1+a_1a_2}\right) + \tan^{-1}\left(\frac{1}{1+a_2a_3}\right) + \dots + \tan^{-1}\left(\frac{1}{1+a_{2021}a_{2022}}\right)$ is equal to :
 (A) $\frac{\pi}{2} - \cot^{-1}(2022)$ (B) $\cot^{-1}(2022) - \frac{\pi}{4}$
 (C) $\tan^{-1}(2022) - \frac{\pi}{4}$ (D) $\frac{\pi}{4} - \tan^{-1}(2022)$
75. The parabolas : $ax^2 + 2bx + cy = 0$ and $dx^2 + 2ex + fy = 0$ intersect on the line $y = 1$. If a, b, c, d, e, f are positive real numbers and a, b, c are in G.P., then
 (A) d, e, f are in A.P. (B) $\frac{d}{a}, \frac{e}{b}, \frac{f}{c}$ are in G.P.
 (C) $\frac{d}{a}, \frac{e}{b}, \frac{f}{c}$ are in A.P. (D) d, e, f are in G.P.

76. If a plane passes through the points $(-1, k, 0)$, $(2, k, -1)$, $(1, 1, 2)$ and is parallel to the line $\frac{x-1}{1} = \frac{2y+1}{2} = \frac{z+1}{-1}$, then the value of $\frac{k^2+1}{(k-1)(k-2)}$ is
- (A) $\frac{17}{5}$ (B) $\frac{5}{17}$ (C) $\frac{6}{13}$ (D) $\frac{13}{6}$
77. Let $a, b, c > 1$, a^3, b^3 and c^3 be in A.P., and $\log_a b, \log_c a$ and $\log_b c$ be in G.P. If the sum of first 20 terms of an A.P., whose first term is $\frac{a+4b+c}{3}$ and common difference is $\frac{a-8b+c}{10}$ is -444 , then abc is equal to
- (A) 343 (B) 216 (C) $\frac{343}{8}$ (D) $\frac{125}{8}$
78. Let S be the set of all values of a_1 for which the mean deviation about the mean of 100 consecutive positive integers $a_1, a_2, a_3, \dots, a_{100}$ is 25. Then S is
- (A) ϕ (B) $\{99\}$ (C) \mathbb{N} (D) $\{9\}$
79. $\lim_{n \rightarrow \infty} \frac{3}{n} \left\{ 4 + \left(2 + \frac{1}{n}\right)^2 + \left(2 + \frac{2}{n}\right)^2 + \dots + \left(3 - \frac{1}{n}\right)^2 \right\}$ is equal to :
- (A) 12 (B) $\frac{19}{3}$ (C) 0 (D) 19
80. For $\alpha, \beta \in \mathbb{R}$ suppose the system of linear equations
- $$\begin{aligned} x - y + z &= 5 \\ 2x + 2y + \alpha z &= 8 \\ 3x - y + 4z &= \beta \end{aligned}$$
- has infinitely many solutions. Then α and β are the roots of
- (A) $x^2 - 10x + 16 = 0$ (B) $x^2 + 18x + 56 = 0$
 (C) $x^2 - 18x + 56 = 0$ (D) $x^2 + 14x + 24 = 0$

SECTION - B

81. 50th root of a number x is 12 and 50th root of another number y is 18. Then the remainder obtained on dividing $(x + y)$ by 25 is_____.
82. Let $A = \{1, 2, 3, 5, 8, 9\}$. Then the number of possible functions $f : A \rightarrow A$ such that $f(m \cdot n) = f(m) \cdot f(n)$ for every $m, n \in A$ with $m \cdot n \in A$ is equal to_____.
83. Let $P(a_1, b_1)$ and $Q(a_2, b_2)$ be two distinct points on a circle with center $C(\sqrt{2}, \sqrt{3})$. Let O be the origin and OC be perpendicular to both CP and CQ . If the area of the triangle OCP is $\frac{\sqrt{35}}{2}$, then $a_1^2 + a_2^2 + b_1^2 + b_2^2$ is equal to _____.
84. The 8th common term of the series
- $$S_1 = 3 + 7 + 11 + 15 + 19 + \dots,$$
- $$S_2 = 1 + 6 + 11 + 16 + 21 + \dots$$
- is_____.

85. Let a line L pass through the point P(2, 3, 1) and be parallel to the line $x + 3y - 2z - 2 = 0 = x - y + 2z$. If the distance of L from the point (5, 3, 8) is α , then $3\alpha^2$ is equal to_____.
86. If $\int \sqrt{\sec 2x - 1} dx = \alpha \log_e \left| \cos 2x + \beta + \sqrt{\cos 2x \left(1 + \cos \frac{1}{\beta} x \right)} \right| + \text{constant}$, then $\beta - \alpha$ is equal to _____.
87. If the value of real number $a > 0$ for which $x^2 - 5ax + 1 = 0$ and $x^2 - ax - 5 = 0$ have a common real root is $\frac{3}{\sqrt{2\beta}}$ then β is equal to _____.
88. The number of seven digits odd numbers, that can be formed using all the seven digits 1, 2, 2, 2, 3, 3, 5 is_____.
89. A bag contains six balls of different colours. Two balls are drawn in succession with replacement. The probability that both the balls are of the same colour is p. Next four balls are drawn in succession with replacement and the probability that exactly three balls are of the same colour is q. If $p : q = m : n$, where m and n are coprime, then $m + n$ is equal to_____.
90. Let A be the area of the region
 $\{(x, y) : y \geq x^2, y \geq (1-x)^2, y \leq 2x(1-x)\}$.
Then 540 A is equal to

□ □ □

30-January-2023 (Evening Batch) : JEE Main Paper

ANSWER KEY**Physics****Single Choice Correct**

1. A	2. B	3. A	4. B	5. D
6. D	7. D	8. B	9. D	10. A
11. D	12. D	13. D	14. B	15. B
16. D	17. B	18. D	19. B	20. B

Numerical Value

21. 313	22. 2	23. 88	24. 3	25. 300
26. 4	27. 12	28. 1584	29. 125	30. 54

Chemistry**Single Choice Correct**

31. C	32. A	33. B	34. C	35. D
36. B	37. D	38. B	39. A	40. D
41. B	42. D	43. A	44. A	45. C
46. B	47. C	48. A	49. C	50. B

Numerical Value

51. 150	52. 4	53. 1350	54. 243	55. 3
56. 16	57. 3	58. 6	59. 150	60. 275

Mathematics**Single Choice Correct**

61. A	62. D	63. A	64. D	65. A
66. C	67. A	68. C	69. A	70. C
71. D	72. A	73. B	74. C	75. C
76. D	77. B	78. C	79. D	80. C

Numerical Value

81. 23	82. 432	83. 24	84. 151	85. 158
86. 1	87. 13	88. 240	89. 14	90. 25