

## 25-January-2023 (Morning Batch) : JEE Main Paper

## PHYSICS

## Section - A (Single Correct Answer)

1. Electron beam used in an electron microscope, when accelerated by a voltage of 20 kV. has a de-Broglie wavelength of  $\lambda_0$ . If the voltage is increased to 40 kV. then the de-Broglie wavelength associated with the electron beam would be:

(A)  $3\lambda_0$                       (B)  $9\lambda_0$                       (C)  $\frac{\lambda_0}{2}$                       (D)  $\frac{\lambda_0}{\sqrt{2}}$

2. An object of mass 8 kg is hanging from one end of a uniform rod CD of mass 2 kg and length 1 m pivoted at its end C on a vertical wall as shown in figure. It is supported by a cable AB such that the system is in equilibrium. The tension in the cable is : (Take  $g = 10 \text{ m/s}^2$ )

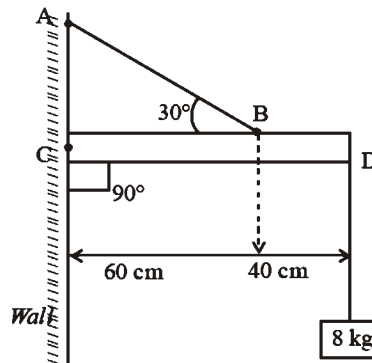

(A) 240 N                      (B) 90 N                      (C) 300 N                      (D) 30 N

3. A Carnot engine with efficiency 50% takes heat from a source at 600 K. In order to increase the efficiency to 70%, keeping the temperature of sink same, the new temperature of the source will be :

(A) 360 K                      (B) 1000 K                      (C) 900 K                      (D) 300 K

4. T is the time period of simple pendulum on the earth's surface. Its time period becomes  $xT$  when taken to a height R (equal to earth's radius) above the earth's surface. Then, the value of  $x$  will be:

(A) 4                      (B) 2                      (C) 1/2                      (D) 1/4

5. Assume that the earth is a solid sphere of uniform density and a tunnel is dug along its diameter throughout the earth. It is found that when a particle is released in this tunnel, it executes a simple harmonic motion. The mass of the particle is 100 g. The time period of the motion of the particle will be (approximately) (take  $g = 10 \text{ ms}^{-2}$ , radius of earth = 6400 km)

(A) 24 hours                      (B) 1 hour 24 minutes  
(C) 1 hour 40 minutes                      (D) 12 hours

6. A car travels a distance of 'x' with speed  $V_1$  and then same distance 'x' with speed  $V_2$  in the same direction. The average speed of the car is:

(A)  $\frac{v_1 v_2}{2(v_1 + v_2)}$                       (B)  $\frac{v_1 + v_2}{2}$                       (C)  $\frac{2x}{v_1 + v_2}$                       (D)  $\frac{2v_1 v_2}{v_1 + v_2}$

7. A parallel plate capacitor has plate area  $40 \text{ cm}^2$  and plates separation 2 mm. The space between the plates is filled with a dielectric medium of a thickness 1 mm and dielectric constant 5. The capacitance of the system is :

(A)  $24\epsilon_0 F$                       (B)  $\frac{3}{10}\epsilon_0 F$                       (C)  $\frac{10}{3}\epsilon_0 F$                       (D)  $10\epsilon_0 F$

8. The root mean square velocity of molecules of gas is  
 (A) Proportional to square of temperature ( $T^2$ ).  
 (B) Inversely proportional to square root of temperature  $\sqrt{\frac{1}{T}}$   
 (C) Proportional to square root of temperature  $\sqrt{T}$   
 (D) Proportional to temperature (T).
9. Match List I with List II
- |   |  |
|---|--|
| <p><b>List - I</b></p> <p>A. Surface tension<br/>                 B. Pressure<br/>                 C. Viscosity<br/>                 D. Impulse</p> | <p><b>List - II</b></p> <p>I. <math>\text{Kg m}^{-1} \text{s}^{-1}</math><br/>                 II. <math>\text{Kg ms}^{-1}</math><br/>                 III. <math>\text{Kg m}^{-1} \text{s}^{-2}</math><br/>                 IV. <math>\text{Kg s}^{-2}</math></p> |
|---|--|
- Choose the correct answer from the options given below :
- (A) A  $\rightarrow$  IV, B  $\rightarrow$  III, C  $\rightarrow$  II, D  $\rightarrow$  I  
 (B) A  $\rightarrow$  IV, B  $\rightarrow$  III, C  $\rightarrow$  I, D  $\rightarrow$  II  
 (C) A  $\rightarrow$  III, B  $\rightarrow$  IV, C  $\rightarrow$  I, D  $\rightarrow$  II  
 (D) A  $\rightarrow$  II, B  $\rightarrow$  I, C  $\rightarrow$  III, D  $\rightarrow$  IV
10. In an LC oscillator, if values of inductance and capacitance become twice and eight times, respectively, then the resonant frequency of oscillator becomes x times its initial resonant frequency  $\omega_0$ . The value of x is:  
 (A) 1/4 (B) 16 (C) 1/16 (D) 4
11. The ratio of the density of oxygen nucleus ( $^{16}_8\text{O}$ ) and helium nucleus ( $^4_2\text{He}$ ) is  
 (A) 4 : 1 (B) 8 : 1 (C) 1 : 1 (D) 2 : 1
12. A message signal of frequency 5 kHz is used to modulate a carrier signal of frequency 2 MHz. The bandwidth for amplitude modulation is:  
 (A) 5 kHz (B) 20 kHz (C) 10 kHz (D) 2.5 kHz
13. All electromagnetic wave is transporting energy in the negative z direction. At a certain point and certain time the direction of electric field of the wave is along positive y direction. What will be the direction of the magnetic field of the wave at that point and instant?  
 (A) Positive direction of x (B) Positive direction of z  
 (C) Negative direction of x (D) Negative direction of y
14. In Young's double slits experiment, the position of 5<sup>th</sup> bright fringe from the central maximum is 5 cm. The distance between slits and screen is 1 m and wavelength of used monochromatic light is 600 nm. The separation between the slits is:  
 (A) 60  $\mu\text{m}$  (B) 48  $\mu\text{m}$  (C) 12  $\mu\text{m}$  (D) 36  $\mu\text{m}$

15. Match List I with List II

**List - I**  
 (Current configuration)

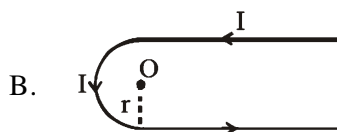
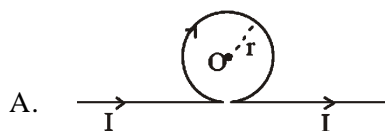

**List - II**  
 (Magnetic field at point O)

I.  $B_0 = \frac{\mu_0 I}{4\pi r} [\pi + 2]$

II.  $B_0 = \frac{\mu_0 I}{4 r}$

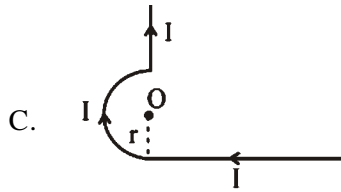

III.  $B_0 = \frac{\mu_0 I}{2\pi r} [\pi - 1]$



IV.  $B_0 = \frac{\mu_0 I}{4\pi r} [\pi + 1]$

Choose the correct answer from the option given below:

- (A) A  $\rightarrow$  III, B  $\rightarrow$  IV, C  $\rightarrow$  I, D  $\rightarrow$  II      (B) A  $\rightarrow$  I, B  $\rightarrow$  III, C  $\rightarrow$  IV, D  $\rightarrow$  II  
 (C) A  $\rightarrow$  III, B  $\rightarrow$  I, C  $\rightarrow$  IV, D  $\rightarrow$  II      (D) A  $\rightarrow$  II, B  $\rightarrow$  I, C  $\rightarrow$  IV, D  $\rightarrow$  III

16. Given below are two statements : one is labeled as **Assertion A** and the other is labeled as **Reason R**

**Assertion A:** Photodiodes are used in forward bias usually for measuring the light intensity.

**Reason R:** For a p-n junction diode, at applied voltage V the current in the forward bias is more than the current in the reverse bias for  $|V_z| > \pm V \geq |V_0|$  where  $V_0$  is the threshold voltage and  $V_z$  is the breakdown voltage.

In the light of the above statements, choose the **correct** answer from the options given below

- (A) Both A and R are true and R is correct explanation A  
 (B) Both A and R are true but R is NOT the correct explanation A  
 (C) A is false but R is true  
 (D) A is true but R is false
17. A solenoid of 1200 turns is wound uniformly in a single layer on a glass tube 2 m long and 0.2 m in diameter. The magnetic intensity at the center of the solenoid when a current of 2 A flows through it is:  
 (A)  $2.4 \times 10^3 \text{ A m}^{-1}$       (B)  $1.2 \times 10^3 \text{ A m}^{-1}$       (C)  $1 \text{ A m}^{-1}$       (D)  $2.4 \times 10^{-3} \text{ A m}^{-1}$
18. A uniform metallic wire carries a current 2 A. when 3.4 V battery is connected across it. The mass of uniform metallic wire is  $8.92 \times 10^{-3} \text{ kg}$ . density is  $8.92 \times 10^3 \text{ kg/m}^3$  and resistivity is  $1.7 \times 10^{-8} \Omega\text{-m}$ . The length of wire is :  
 (A)  $l = 6.8 \text{ m}$       (B)  $l = 10 \text{ m}$       (C)  $l = 5 \text{ m}$       (D)  $l = 100 \text{ m}$
19. A bowl filled with very hot soup cools from  $98^\circ\text{C}$  to  $86^\circ\text{C}$  in 2 minutes when the room temperature is  $22^\circ\text{C}$ . How long it will take to cool from  $75^\circ\text{C}$  to  $69^\circ\text{C}$  ?  
 (A) 2 minutes      (B) 1.4 minutes      (C) 0.5 minute      (D) 1 minute
20. A car is moving with a constant speed of 20 m/s in a circular horizontal track of radius 40 m. A bob is suspended from the roof of the car by a massless string. The angle made by the string with the vertical will be : (Take  $g = 10 \text{ m/s}^2$ )  
 (A)  $\frac{\pi}{6}$       (B)  $\frac{\pi}{2}$       (C)  $\frac{\pi}{4}$       (D)  $\frac{\pi}{3}$

### SECTION - B

21. A ray of light is incident from air on a glass plate having thickness  $\sqrt{3} \text{ cm}$  and refractive index  $\sqrt{2}$ . The angle of incidence of a ray is equal to the critical angle for glass-air interface. The lateral displacement of the ray when it passes through the plate is  $\_\_\_ \times 10^{-2} \text{ cm}$ . (given  $\sin 15^\circ = 0.26$ )

22. In the given circuit, the equivalent resistance between the terminal A and B is \_\_\_\_\_  $\Omega$ .

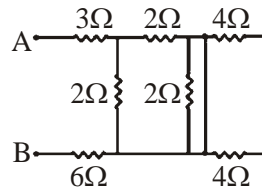

23. As shown in the figure, in an experiment to determine Young's modulus of a wire, the extension-load curve is plotted. The curve is a straight line passing through the origin and makes an angle of  $45^\circ$  with the load axis. The length of wire is 62.8 cm and its diameter is 4 mm. The Young's modulus is found to be  $x \times 10^4 \text{ Nm}^{-2}$ . The value of  $x$  is \_\_\_\_\_.

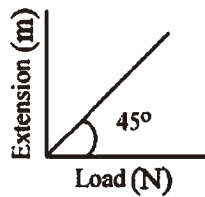

24. An object of mass 'm' initially at rest on a smooth horizontal plane starts moving under the action of force  $F = 2\text{N}$ . In the process of its linear motion, the angle  $\theta$  (as shown in figure) between the direction of force and horizontal varies as  $\theta = kx$ , where  $k$  is a constant and  $x$  is the distance covered by the object from its initial position. The expression of kinetic energy of the object will be  $E = \frac{n}{k} \sin \theta$ . The value of  $n$  is \_\_\_\_\_.

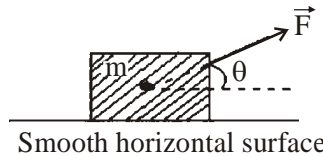

25. The wavelength of the radiation emitted is  $\lambda_0$  when an electron jumps from the second excited state to the first excited state of hydrogen atom. If the electron jumps from the third excited state to the second orbit of the hydrogen atom, the wavelength of the radiation emitted will be  $\frac{20}{x} \lambda_0$ . The value of  $x$  is \_\_\_\_\_.

26.  $I_{CM}$  is moment of inertia of a circular disc about an axis (CM) passing through its center and perpendicular to the plane of disc.  $I_{AB}$  is its moment of inertia about an axis AB perpendicular to plane and parallel to axis CM at a distance  $\frac{2}{3}R$  from center. Where  $R$  is the radius of the disc. The ratio of  $I_{AB}$  and  $I_{CM}$  is  $x : 9$ . The value of  $x$  is \_\_\_\_\_.

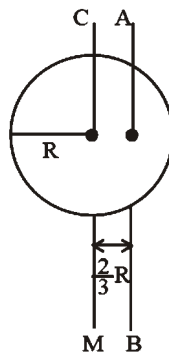

27. The distance between two consecutive points with phase difference of  $60^\circ$  in a wave of frequency 500 Hz is 6.0 m. The velocity with which wave is traveling is \_\_\_\_\_ km/s
28. A uniform electric field of 10 N/C is created between two parallel charged plates (as shown in figure). An electron enters the field symmetrically between the plates with a kinetic energy 0.5 eV. The length of each plate is 10 cm. The angle ( $\theta$ ) of deviation of the path of electron as it comes out of the field is \_\_\_\_ (in degree).

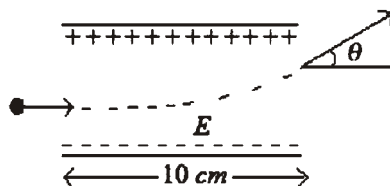

29. An LCR series circuit of capacitance 62.5 nF and resistance of  $50 \Omega$ . is connected to an A.C. source of frequency 2.0 kHz. For maximum value of amplitude of current in circuit, the value of inductance is \_\_\_\_\_ mH. (take  $\pi^2 = 10$ )
30. If  $\vec{P} = 3\hat{i} + \sqrt{3}\hat{j} + 2\hat{k}$  and  $\vec{Q} = 4\hat{i} + \sqrt{3}\hat{j} + 2.5\hat{k}$  then, the unit vector in the direction of  $\vec{P} \times \vec{Q}$  is  $\frac{1}{x}(\sqrt{3}\hat{i} + \hat{j} - 2\sqrt{3}\hat{k})$ . The value of x is

---

**CHEMISTRY** **Section - A (Single Correct Answer)**

---

31. The compound which will have the lowest rate towards nucleophilic aromatic substitution on treatment with  $\text{OH}^-$  is

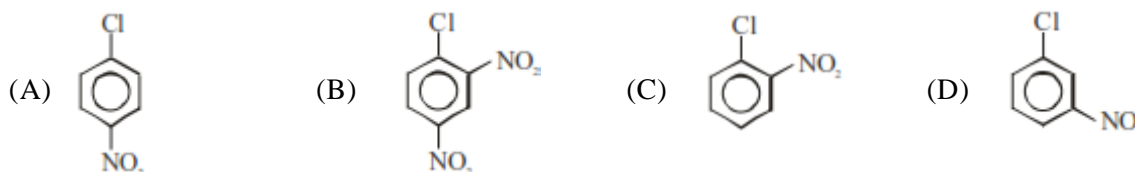

32. The variation of the rate of an enzyme catalyzed reaction with substrate concentration is correctly represented by graph.

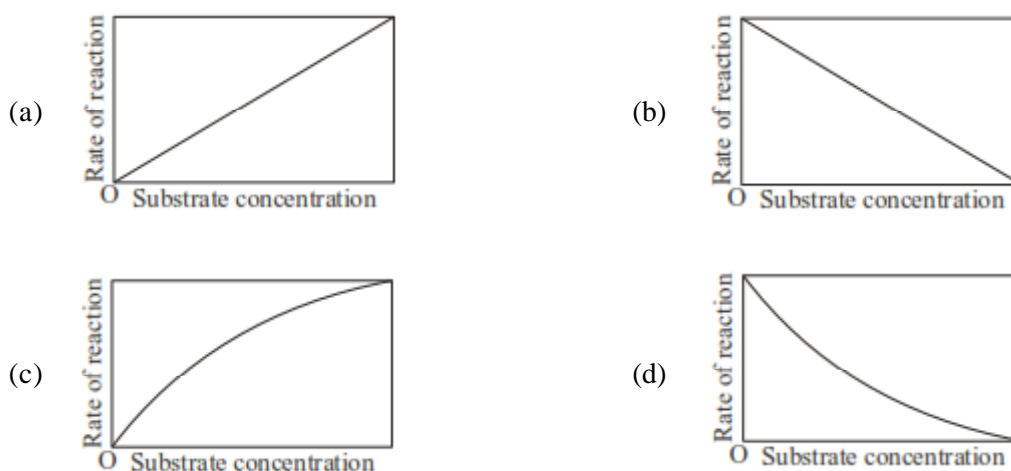

- (A) b (B) c  
(C) d (D) a

33. Identify the product formed (A and E).

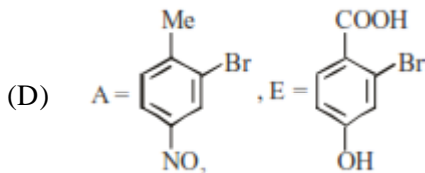
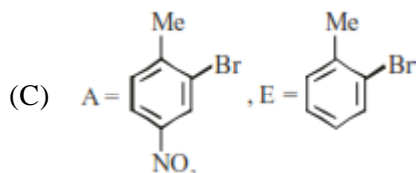
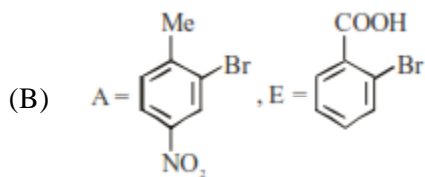
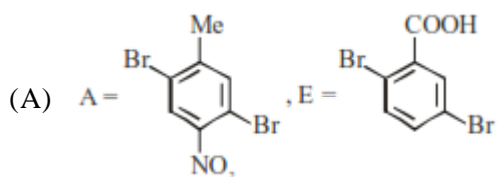
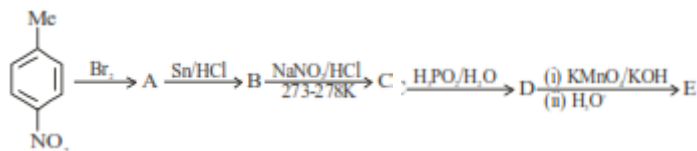

34. Match List I with List II.

List I		List II	
Elements		Colour imparted to the flame	
A	K	I	Brick Red
B	Ca	II	Violet
C	Sr	III	Apple Green
D	Ba	IV	Crimson Red

Choose the correct answer from the options given below.

(A) A-II, B-I, C-III, D-IV

(B) A-II, B-IV, C-I, D-III

(C) A-II, B-I, C-IV, D-III

(D) A-IV, B-III, C-II, D-I

35. Reaction of thionyl chloride with white phosphorus forms a compound [A], which on hydrolysis gives [B], a dibasic acid. [A] and [B] are respectively.

(A)  $P_4O_6$  and  $H_3PO_3$

(B)  $PCl_3$  and  $H_3PO_3$

(C)  $PCl_5$  and  $H_3PO_4$

(D)  $POCl_3$  and  $H_3PO_4$

36. A cubic solid is made up of two elements X and Y. Atoms of X are present on every alternate corner and

one at the center of cube. Y is at  $\frac{1}{3}$ rd of the total faces. The empirical formula of the compound is

(A)  $X_2Y_{1.5}$

(B)  $X_{2.5}Y$

(C)  $XY_{2.5}$

(D)  $X_{1.5}Y_2$

37. The radius of the 2<sup>nd</sup> orbit of  $Li^{2+}$  is x. The expected radius of the 3<sup>rd</sup> orbit of  $Be^{3+}$  is

(A)  $\frac{9}{4}x$

(B)  $\frac{4}{9}x$

(C)  $\frac{27}{16}x$

(D)  $\frac{16}{27}x$

38. Which of the following conformations will be the most stable ?

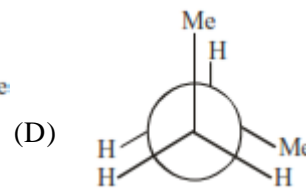
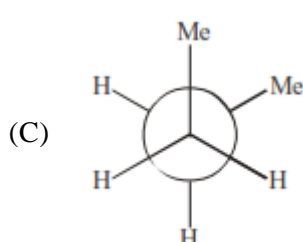
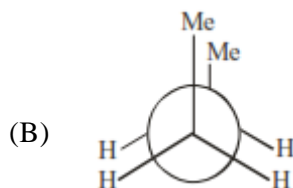
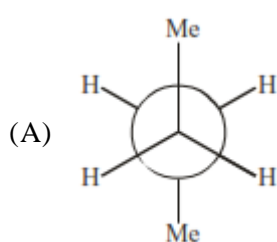

39. Match items of Row I with those of Row II.

**Row I :**

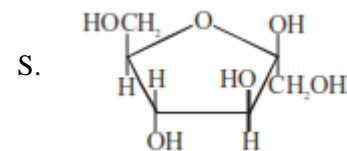
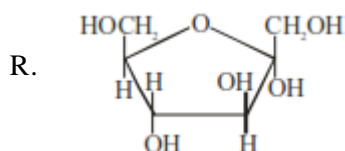
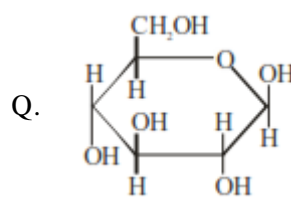
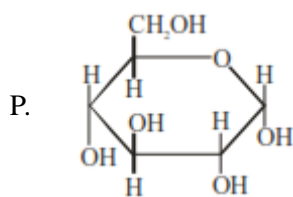

**Row II :**

i.  $\alpha$ -D-(-) Fructofuranose

ii.  $\beta$ -D-(-) Fructofuranose

iii.  $\alpha$ -D-(-) Glucopyranose

iv.  $\beta$ -D-(-) Glucopyranose

**Correct** match is

(A) P  $\rightarrow$  iv, Q  $\rightarrow$  iii, R  $\rightarrow$  i, S  $\rightarrow$  ii

(B) P  $\rightarrow$  i, Q  $\rightarrow$  ii, R  $\rightarrow$  iii, S  $\rightarrow$  iv

(C) P  $\rightarrow$  iii, Q  $\rightarrow$  iv, R  $\rightarrow$  ii, S  $\rightarrow$  i

(D) P  $\rightarrow$  iii, Q  $\rightarrow$  iv, R  $\rightarrow$  i, S  $\rightarrow$  ii

40. Given below are two statements : one is labelled as Assertion A and the other is labelled as Reason R :

**Assertion A :** Acetal/Ketal is stable in basic medium.

**Reason R :** The high leaving tendency of alkoxide ion gives the stability to acetal/ketal in basic medium.

In the light of the above statements, choose the **correct** answer from the options given below.

(A) A is true but R is false

(B) A is false but R is true

(C) Both A and R are true and R is the correct explanation of A

(D) Both A and R are true but R is NOT the correct explanation of A

41. Inert gases have positive electron gain enthalpy. Its **correct** order is

(A) Xe < Kr < Ne < He

(B) He < Ne < Kr < Xe

(C) He < Xe < Kr < Ne

(D) He < Kr < Xe < Ne

42. Which one of the following reactions does not occur during extraction of copper ?

(A)  $2\text{Cu}_2\text{S} + 3\text{O}_2 \rightarrow 2\text{Cu}_2\text{O} + 2\text{SO}_2$

(B)  $2\text{FeS} + 3\text{O}_2 \rightarrow 2\text{FeO} + 2\text{SO}_2$

(C)  $\text{CaO} + \text{SiO}_2 \rightarrow \text{CaSiO}_3$

(D)  $\text{FeO} + \text{SiO}_2 \rightarrow \text{FeSiO}_3$

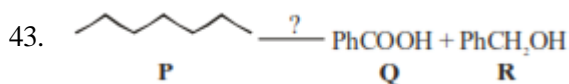

The **correct** sequence of reagents for the pre-paration of Q and R is :

(A) (i)  $\text{Cr}_2\text{O}_3$ , 770 K, 20 atm ;

(ii)  $\text{CrO}_2\text{Cl}_2$ ,  $\text{H}_3\text{O}^+$  ;

(iii) NaOH ;

(iv)  $\text{H}_3\text{O}^+$

(B) (i)  $\text{CrO}_2\text{Cl}_2$ ,  $\text{H}_3\text{O}^+$  ;

(ii)  $\text{Cr}_2\text{O}_3$ , 770 K, 20 atm ;

(iii) NaOH ;

(iv)  $\text{H}_3\text{O}^+$

(C) (i)  $\text{KMnO}_4$ ,  $\text{OH}^-$  ;

(ii)  $\text{Mo}_2\text{O}_3$ ,  $\Delta$  ;

(iii) NaOH ;

(iv)  $\text{H}_3\text{O}^+$

(D) (i)  $\text{Mo}_2\text{O}_3$ ,  $\Delta$  ;

(ii)  $\text{CrO}_2\text{Cl}_2$ ,  $\text{H}_3\text{O}^+$  ;

(iii) NaOH ;

(iv)  $\text{H}_3\text{O}^+$

44. The **correct** order in aqueous medium of basic strength in case of methyl substituted amines is  
 (A)  $\text{Me}_2\text{NH} > \text{MeNH}_2 > \text{Me}_3\text{N} > \text{NH}_3$  (B)  $\text{Me}_2\text{NH} > \text{Me}_3\text{N} > \text{MeNH}_2 > \text{NH}_3$   
 (C)  $\text{NH}_3 > \text{Me}_3\text{N} > \text{MeNH}_2 > \text{Me}_2\text{NH}$  (D)  $\text{Me}_3\text{N} > \text{Me}_2\text{NH} > \text{MeNH}_2 > \text{NH}_3$
45. '25 volume' hydrogen peroxide means –  
 (A) 1 L marketed solution contains 250 g of  $\text{H}_2\text{O}_2$ .  
 (B) 1 L marketed solution contains 75 g of  $\text{H}_2\text{O}_2$ .  
 (C) 100 mL marketed solution contains 25 g of  $\text{H}_2\text{O}_2$ .  
 (D) 1 L marketed solution contains 25 g of  $\text{H}_2\text{O}_2$ .
46. Which of the following statements is incorrect for antibiotics ?  
 (A) An antibiotic must be a product of meta-bolism.  
 (B) An antibiotic is a synthetic substance produced as a structural analogue of naturally occurring antibiotic.  
 (C) An antibiotic should promote the growth or survival of microorganisms.  
 (D) An antibiotic should be effective in low concentrations.
47. Compound A reacts with  $\text{NH}_4\text{Cl}$  and forms a compound B. Compound B reacts with  $\text{H}_2\text{O}$  and excess of  $\text{CO}_2$  to form compound C which on passing through or reaction with saturated  $\text{NaCl}$  solution forms sodium hydrogen carbonate.  
 Compound A, B and C, are respectively.  
 (A)  $\text{CaCl}_2$ ,  $\text{NH}_3$ ,  $\text{NH}_4\text{HCO}_3$  (B)  $\text{CaCl}_2$ ,  $\text{NH}_4^+$ ,  $(\text{NH}_4)_2\text{CO}_3$   
 (C)  $\text{Ca}(\text{OH})_2$ ,  $\text{NH}_3$ ,  $\text{NH}_4\text{HCO}_3$  (D)  $\text{Ca}(\text{OH})_2$ ,  $\text{NH}_4^+$ ,  $(\text{NH}_4)_2\text{CO}_3$
48. Some reactions of  $\text{NO}_2$  relevant to photochemical smog formation are

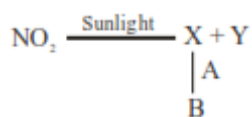

Identify A, B, X and Y.

- (A)  $\text{X} = [\text{O}]$ ,  $\text{Y} = \text{NO}$ ,  $\text{A} = \text{O}_2$ ,  $\text{B} = \text{O}_3$  (B)  $\text{X} = \text{N}_2\text{O}$ ,  $\text{Y} = [\text{O}]$ ,  $\text{A} = \text{O}_3$ ,  $\text{B} = \text{NO}$   
 (C)  $\text{X} = \frac{1}{2}\text{O}_2$ ,  $\text{Y} = \text{NO}_2$ ,  $\text{A} = \text{O}_3$ ,  $\text{B} = \text{O}_2$  (D)  $\text{X} = \text{NO}$ ,  $\text{Y} = [\text{O}]$ ,  $\text{A} = \text{O}_2$ ,  $\text{B} = \text{N}_2\text{O}_3$
49. Match the List-I with List-II :

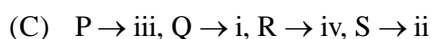
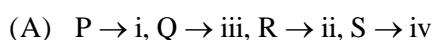
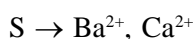
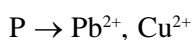
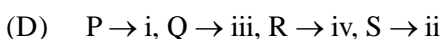
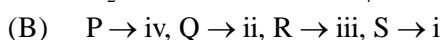
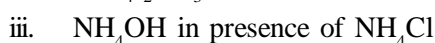
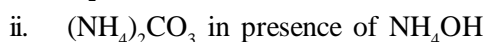
**List-I [Cations]****List-II [Group reaction]**

50. In the cumene to phenol preparation in presence of air, the intermediate is

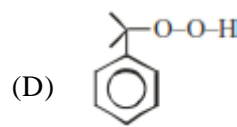
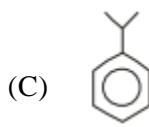
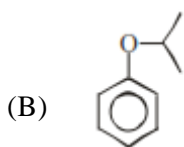
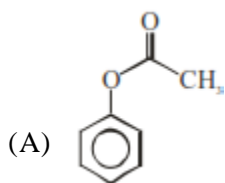



**SECTION - B**

51. An athlete is given 100 g of glucose ( $C_6H_{12}O_6$ ) for energy. This is equivalent to 1800 kJ of energy. The 50% of this energy gained is utilized by the athlete for sports activities at the event. In order to avoid storage of energy, the weight of extra water he would need to perspire is \_\_\_\_\_ g.

(Nearest integer)

Assume that there is no other way of consuming stored energy.

**Given :** The enthalpy of evaporation of water is  $45 \text{ kJ mol}^{-1}$ .

Molar mass of C, H & O are 12, 1 &  $16 \text{ g mol}^{-1}$ .

52. A litre of buffer solution contains 0.1 mole of each of  $NH_3$  and  $NH_4Cl$ . On the addition of 0.02 mole of HCl by dissolving gaseous HCl, the pH of the solution is found to be \_\_\_\_\_  $\times 10^{-3}$ .

(Nearest integer)

[**Given :**  $pK_b(NH_3) = 4.745$

$\log 2 = 0.301$

$\log 3 = 0.477$

$T = 298 \text{ K}$ ]

53. The osmotic pressure of solutions of PVC in cyclohexanone at 300 K are plotted on the graph. The molar mass of PVC is \_\_\_\_\_  $\text{g mol}^{-1}$ . (Nearest integer)

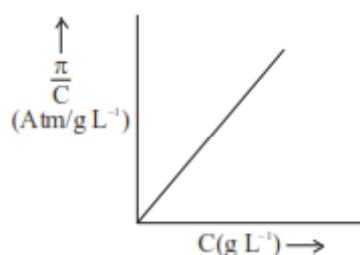

(**Given :**  $R = 0.083 \text{ L atm K}^{-1} \text{ mol}^{-1}$ )

54. How many of the following metal ions have similar value of spin only magnetic moment in gaseous state ?

-----

(**Given :** Atomic no. : V, 23 ; Cr, 24 ; Fe, 26 ; Ni, 28)

$V^{3+}$ ,  $Cr^{3+}$ ,  $Fe^{2+}$ ,  $Ni^{3+}$

55. The density of a monobasic strong acid (Molar mass  $24.2 \text{ g mol}^{-1}$ ) is  $1.21 \text{ kg L}^{-1}$ . The volume of its solution required for the complete neutralization of 25 mL of 0.24 M NaOH is \_\_\_\_\_  $\times 10^{-2} \text{ mL}$ .

(Nearest integer)

56. For the first order reaction  $A \rightarrow B$  the half life is 30 min. The time taken for 75% completion of the reaction is \_\_\_\_\_ min. (Nearest integer)

**Given :**  $\log 2 = 0.3010$

$\log 3 = 0.4771$

$\log 5 = 0.6989$

57. The total number of lone pairs of electrons on oxygen atoms of ozone is \_\_\_\_\_.

58. In sulphur estimation. 0.471 g of an organic compound gave 1.4439 g of barium sulphate.

The percentage of sulphur in the compound is \_\_\_\_\_.

(Nearest Integer)

(**Given :** Atomic mass : Ba : 137 u ; S : 32 u ; O : 16 u )

59. The number of paramagnetic species from the following is \_\_\_\_.

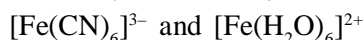
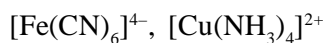

60. Consider the cell

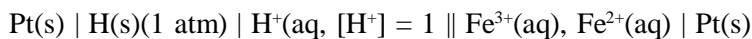

**Given :**  $E^\circ_{\text{Fe}^{3+}/\text{Fe}^{2+}} = 0.771 \text{ V}$  and

$$E^\circ_{\text{H}^+/\frac{1}{2}\text{H}_2} = 0 \text{ V}, T = 298 \text{ K}$$

If the potential of the cell is 0.712 V the ratio of concentration of  $\text{Fe}^{3+}$  to  $\text{Fe}^{2+}$  is \_\_\_\_.

(Nearest integer)

## MATHEMATICS

### Section - A (Single Correct Answer)

61. Let  $M$  be the maximum value of the product of two positive integers when their sum is 66. Let the sample

space  $S = \left\{ x \in \mathbb{Z} : x(66-x) \geq \frac{5}{9}M \right\}$  and the event  $A = \{ x \in S : x \text{ is a multiple of } 3 \}$ . Then  $P(A)$  is equal to

(A)  $\frac{15}{44}$

(B)  $\frac{1}{3}$

(C)  $\frac{1}{6}$

(D)  $\frac{7}{22}$

62. Let  $\vec{a}$ ,  $\vec{b}$  and  $\vec{c}$  be three non zero vectors such that  $\vec{b} \cdot \vec{c} = 0$  and  $\vec{a} \times (\vec{b} \times \vec{c}) = \frac{\vec{b} - \vec{c}}{2}$ . If  $\vec{d}$  be a vector such that  $\vec{b} \cdot \vec{d} = \vec{a} \cdot \vec{b}$ , then  $(\vec{a} \times \vec{b}) \cdot (\vec{c} \times \vec{d})$  is equal to

(A)  $\frac{3}{4}$

(B)  $\frac{1}{2}$

(C)  $-\frac{1}{4}$

(D)  $\frac{1}{4}$

63. Let  $y = y(x)$  be the solution curve of the differential equation  $\frac{dy}{dx} = \frac{y}{x}(1 + xy^2(1 + \log_e x))$ ,  $x > 0$ ,  $y(1) = 3$ .

Then  $\frac{y^2(x)}{9}$  is equal to :

(A)  $\frac{x^2}{5 - 2x^3(2 + \log_e x^3)}$

(B)  $\frac{x^2}{2x^3(2 + \log_e x^3) - 3}$

(C)  $\frac{x^2}{3x^3(1 + \log_e x^2) - 2}$

(D)  $\frac{x^2}{7 - 3x^3(2 + \log_e x^2)}$

64. The value of  $\lim_{n \rightarrow \infty} \frac{1+2-3+4+5-6+\dots+(3n-2)+(3n-1)-3n}{\sqrt{2n^4+4n+3}-\sqrt{n^4+5n+4}}$  is :

(A)  $\frac{\sqrt{2}+1}{2}$

(B)  $3(\sqrt{2}+1)$

(C)  $\frac{3}{2}(\sqrt{2}+1)$

(D)  $\frac{3}{2\sqrt{2}}$

65. The points of intersection of the line  $ax + by = 0$ , ( $a \neq b$ ) and the circle  $x^2 + y^2 - 2x = 0$  are  $A(\alpha, 0)$  and  $B(1, \beta)$ . The image of the circle with  $AB$  as a diameter in the line  $x + y + 2 = 0$  is :
- (A)  $x^2 + y^2 + 5x + 5y + 12 = 0$  (B)  $x^2 + y^2 + 3x + 5y + 8 = 0$   
 (C)  $x^2 + y^2 + 3x + 3y + 4 = 0$  (D)  $x^2 + y^2 - 5x - 5y + 12 = 0$
66. The mean and variance of the marks obtained by the students in a test are 10 and 4 respectively. Later, the marks of one of the students is increased from 8 to 12. If the new mean of the marks is 10.2. then their new variance is equal to :
- (A) 4.04 (B) 4.08 (C) 3.96 (D) 3.92
67. Let  $y(x) = (1 + x)(1 + x^2)(1 + x^4)(1 + x^8)(1 + x^{16})$ . Then  $y' - y''$  at  $x = -1$  is equal to :
- (A) 976 (B) 464 (C) 496 (D) 944
68. The vector  $\vec{a} = -\hat{i} + 2\hat{j} + \hat{k}$  is rotated through a right angle, passing through the  $y$ -axis in its way and the resulting vector is  $\vec{b}$ . Then the projection of  $3\vec{a} + \sqrt{2}\vec{b}$  on  $\vec{c} = 5\hat{i} + 4\hat{j} + 3\hat{k}$  is
- (A)  $3\sqrt{2}$  (B) 1 (C)  $\sqrt{6}$  (D)  $2\sqrt{3}$
69. The minimum value of the function  $f(x) = \int_0^x e^{x-t} dt$  is
- (A)  $2(e - 1)$  (B)  $2e - 1$   
 (C) 2 (D)  $e(e - 1)$
70. Consider the lines  $L_1$  and  $L_2$  given by
- $$L_1 : \frac{x-1}{2} = \frac{y-3}{1} = \frac{z-2}{2}$$
- $$L_2 : \frac{x-2}{1} = \frac{y-2}{2} = \frac{z-3}{3}$$
- A line  $L_3$  having direction ratios 1, -1, -2, intersects  $L_1$  and  $L_2$  at the points P and Q respectively. Then the length of line segment PQ is
- (A)  $2\sqrt{6}$  (B)  $3\sqrt{2}$  (C)  $4\sqrt{3}$  (D) 4
71. Let  $x = 2$  be a local minima of the function  $f(x) = 2x^4 - 18x^2 + 8x + 12$ ,  $x \in (-4, 4)$ . If M is local maximum value of the function  $f$  in  $(-4, 4)$ , then  $M =$
- (A)  $12\sqrt{6} - \frac{33}{2}$  (B)  $12\sqrt{6} - \frac{31}{2}$  (C)  $18\sqrt{6} - \frac{33}{2}$  (D)  $18\sqrt{6} - \frac{31}{2}$
72. Let  $z_1 = 2 + 3i$  and  $z_2 = 3 + 4i$ . The set  $S = \{z \in \mathbb{C} : |z - z_1|^2 - |z - z_2|^2 = |z_1 - z_2|^2\}$  represents a
- (A) straight line with sum of its intercepts on the coordinate axes equals 14  
 (B) hyperbola with the length of the transverse axis 7  
 (C) straight line with the sum of its intercepts on the coordinate axes equals -18  
 (D) hyperbola with eccentricity 2
73. The distance of the point  $(6, -2\sqrt{2})$  from the common tangent  $y = mx + c$ ,  $m > 0$ , of the curves  $x = 2y^2$  and  $x = 1 + y^2$  is
- (A)  $\frac{1}{3}$  (B) 5 (C)  $\frac{14}{3}$  (D)  $5\sqrt{3}$

74. Let  $S_1$  and  $S_2$  be respectively the sets of all  $a \in \mathbb{R} - \{0\}$  for which the system of linear equations
- $$ax + 2ay - 3az = 1$$
- $$(2a + 1)x + (2a + 3)y + (a + 1)z = 2$$
- $$(3a + 5)x + (a + 5)y + (a + 2)z = 3$$
- has unique solution and infinitely many solutions. Then
- (A)  $n(S_1) = 2$  and  $S_2$  is an infinite set      (B)  $S_1$  is an infinite set and  $n(S_2) = 2$   
 (C)  $S_1 = \Phi$  and  $S_2 = \mathbb{R} - \{0\}$       (D)  $S_1 = \mathbb{R} - \{0\}$  and  $S_2 = \Phi$
75. Let  $f(x) = \int \frac{2x}{(x^2 + 1)(x^2 + 3)} dx$ .
- If  $f(3) = \frac{1}{2}(\log_e 5 - \log_e 6)$ , then  $f(4)$  is equal to
- (A)  $\frac{1}{2}(\log_e 17 - \log_e 19)$       (B)  $\log_e 17 - \log_e 18$   
 (C)  $\frac{1}{2}(\log_e 19 - \log_e 17)$       (D)  $\log_e 19 - \log_e 20$
76. The statement  $(p \wedge (\sim q)) \Rightarrow (p \Rightarrow (\sim q))$  is
- (A) equivalent to  $(\sim p) \vee (\sim q)$       (B) a tautology  
 (C) equivalent to  $p \vee q$       (D) a contradiction
77. Let  $f : (0, 1) \rightarrow \mathbb{R}$  be a function defined by  $f(x) = \frac{1}{1 - e^{-x}}$ , and  $g(x) = (f(-x) - f(x))$ . Consider two statements
- (I)  $g$  is an increasing function in  $(0, 1)$   
 (II)  $g$  is one-one in  $(0, 1)$
- Then,
- (A) Only (I) is true      (B) Only (II) is true  
 (C) Neither (I) nor (II) is true      (D) Both (I) and (II) are true
78. The distance of the point  $P(4, 6, -2)$  from the line passing through the point  $(-3, 2, 3)$  and parallel to a line with direction ratios  $3, 3, -1$  is equal to :
- (A) 3      (B)  $\sqrt{6}$       (C)  $2\sqrt{3}$       (D)  $\sqrt{14}$
79. Let  $x, y, z > 1$  and  $A = \begin{bmatrix} 1 & \log_x y & \log_x z \\ \log_y x & 2 & \log_y z \\ \log_z x & \log_z y & 3 \end{bmatrix}$ ,
- Then  $|\text{adj}(\text{adj} A^2)|$  is equal to
- (A)  $6^4$       (B)  $2^8$       (C)  $4^8$       (D)  $2^4$
80. If  $a_r$  is the coefficient of  $x^{10-r}$  in the Binomial expansion of  $(1 + x)^{10}$ , then  $\sum_{r=1}^{10} r^3 \left( \frac{a_r}{a_{r-1}} \right)^2$  is equal to
- (A) 4895      (B) 1210      (C) 5445      (D) 3025

**SECTION - B**

81. Let  $S = \{1, 2, 3, 5, 7, 10, 11\}$ . The number of nonempty subsets of  $S$  that have the sum of all elements a multiple of 3, is \_\_\_\_\_.
82. For some  $a, b, c \in \mathbb{N}$ , let  $f(x) = ax - 3$  and  $g(x) = x^b + c$ ,  $x \in \mathbb{R}$ . If  $(f \circ g)^{-1}(x) = \left(\frac{x-7}{2}\right)^{1/3}$ , then  $(f \circ g)(ac) + (g \circ f)(b)$  is equal to \_\_\_\_\_.
83. The vertices of a hyperbola  $H$  are  $(\pm 6, 0)$  and its eccentricity is  $\frac{\sqrt{5}}{2}$ . Let  $N$  be the normal to  $H$  at a point in the first quadrant and parallel to the line  $\sqrt{2}x + y = 2\sqrt{2}$ . If  $d$  is the length of the line segment of  $N$  between  $H$  and the  $y$ -axis then  $d^2$  is equal to \_\_\_\_\_.
84. Let  $S = \left\{ \alpha : \log_2(9^{2\alpha-4} + 13) - \log_2\left(\frac{5}{2} \cdot 3^{2\alpha-4} + 1\right) = 2 \right\}$ . Then the maximum value of  $\beta$  for which the equation  $x^2 - 2\left(\sum_{\alpha \in S} \alpha\right)^2 x + \sum_{\alpha \in S} (\alpha+1)^2 \beta = 0$  has real roots, is \_\_\_\_\_.
85. The constant term in the expansion of  $\left(2x + \frac{1}{x^7} + 3x^2\right)^5$  is \_\_\_\_\_.
86. Let  $A_1, A_2, A_3$  be the three A.P. with the same common difference  $d$  and having their first terms as  $A, A+1, A+2$ , respectively. Let  $a, b, c$  be the 7<sup>th</sup>, 9<sup>th</sup>, 17<sup>th</sup> terms of  $A_1, A_2, A_3$ , respectively such that
- $$\begin{vmatrix} a & 7 & 1 \\ 2b & 17 & 1 \\ c & 17 & 1 \end{vmatrix} + 70 = 0$$
- If  $a = 29$ , then the sum of first 20 terms of an AP whose first term is  $c - a - b$  and common difference is  $\frac{d}{12}$ , is equal to \_\_\_\_\_.
87. If the sum of all the solutions of  $\tan^{-1}\left(\frac{2x}{1-x^2}\right) + \cot^{-1}\left(\frac{1-x^2}{2x}\right) = \frac{\pi}{3}$ ,  $-1 < x < 1$ ,  $x \neq 0$ , is  $\alpha - \frac{4}{\sqrt{3}}$ , then  $\alpha$  is equal to \_\_\_\_\_.
88. Let the equation of the plane passing through the line  $x - 2y - z - 5 = 0 = x + y + 3z - 5$  and parallel to the line  $x + y + 2z - 7 = 0 = 2x + 3y + z - 2$  be  $ax + by + cz = 65$ . Then the distance of the point  $(a, b, c)$  from the plane  $2x + 2y - z + 16 = 0$  is \_\_\_\_\_.
89. Let  $x$  and  $y$  be distinct integers where  $1 \leq x \leq 25$  and  $1 \leq y \leq 25$ . Then, the number of ways of choosing  $x$  and  $y$ , such that  $x + y$  is divisible by 5, is \_\_\_\_\_.
90. If the area enclosed by the parabolas  $P_1 : 2y = 5x^2$  and  $P_2 : x^2 - y + 6 = 0$  is equal to the area enclosed by  $P_1$  and  $y = \alpha x$ ,  $\alpha > 0$ , then  $\alpha^3$  is equal to \_\_\_\_\_.



## 25-January-2023 (Morning Batch) : JEE Main Paper

**ANSWER KEY****Physics****Single Choice Correct**

1. D	2. C	3. B	4. B	5. B
6. D	7. C	8. C	9. B	10. A
11. C	12. C	13. A	14. A	15. C
16. C	17. B	18. B	19. B	20. C

**Numerical Value**

21. 52	22. 10	23. 5	24. 2	25. 27
26. 17	27. 18	28. 45	29. 100	30. 4

**Chemistry****Single Choice Correct**

31. D	32. B	33. B	34. C	35. B
36. B	37. C	38. A	39. D	40. A
41. C	42. C	43. A	44. A	45. B
46. C	47. C	48. A	49. D	50. D

**Numerical Value**

51. 360	52. 9079	53. 41500	54. 2	55. 12
56. 60	57. 6	58. 42	59. 4	60. 10

**Mathematics****Single Choice Correct**

61. B	62. D	63. A	64. C	65. A
66. C	67. C	68. A	69. A	70. A
71. A	72. A	73. B	74. D	75. A
76. B	77. D	78. D	79. B	80. B

**Numerical Value**

81. 43	82. 2039	83. 216	84. 25	85. 1080
86. 495	87. 2	88. 9	89. 120	90. 600